

SB028

Valve Collet Fit and Valve Rotation

Engines are often designed to have the valves rotate. This is done to help prevent localised overheating, carbon build up on the valve seat face, gas leakage from uneven valve face and/or seat wear, valve tip grooving/wear and possible head distortion. It also helps improve valve guide lubrication.

There are two commonly employed techniques, that of allowing the valve to rotate (natural or free) and that of forcing rotation (positive/forced). The desired outcome is achieved by the selection and combination of valve collet design and rotator.

With natural rotation, the two halves of the collets make firm contact with each other when installed. The valve stem is not gripped but is free to rotate inside the collets. This technique is recognised by the multigroove type design where rotation is developed by the twisting action of the spring as it is compressed and released. (Refer Figure 1 below.)

With free and positive/forced action systems, the collets grip the valve and rotation is developed by mechanical rotating devices known as rotators. These devices are located at either one end of the valve spring or the other and movement is created as the valve begins to open. A variation on this is the use of roto-valve caps. As the rocker presses down on the cap, the spring tension is released from the valve, allowing it to rotate. (Refer Figure 2 below.)

It is important to recognise where these systems are being employed and to ensure the collets have the correct fit on the valve.

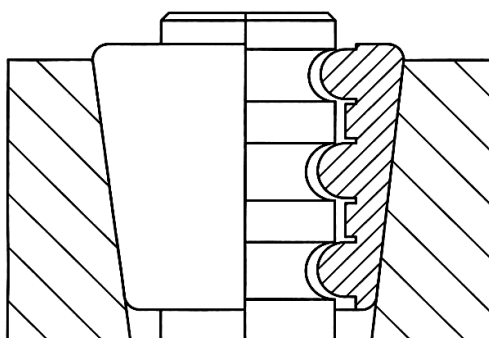

Figure 1. Multigroove collets with two halves butting together.

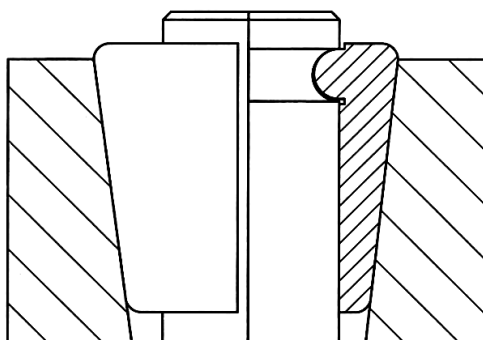

Figure 2. Single groove collets with halves **not** butting, allowing them to grip the valve stem.